

CLASSIC ANR

USERS GUIDE



FLIGHTCOM 

ANR TECHNOLOGY

Special placement of speakers and microphone within the eardome allow the ANR technology to sample a selection of sounds that pose some risk for hearing damage, and create an equal but opposite sound to cancel the noise before it enters your ear.

INSTALLATION

- Insert the larger plug into the jack marked “headphone” or “phone”.
- Insert the smaller plug into the jack marked “microphone” or “mic”.
- Insert 9V battery (included) into the battery compartment.
- Set the stereo/mono switch located beside the belt clip on the battery pack to “M” position. If connecting to a stereo intercom, set the switch to the “S” position.

To activate the ANR, locate the switch at the top of the battery compartment and select “I” for “on”. A Flashing green LED will indicate it is functioning. Return to the “O” position to turn ANR off.

FITTING INSTRUCTIONS

- The mic boom should always be worn from the left side.
- To increase the size of the headset, slide the domes in a downward direction. To decrease, slide the domes in an upward direction.
- Properly fitting the headset to each wearer's head is crucial to performance. The headpad should fit comfortably on top of the head, without a gap or space between the head and headpad. The headset should be centered on the head, and the ear seals should comfortably cover the ears, without being placed too far forward on the jawbone or face. Place the mic no more than 1/8" from the lips to ensure clarity and peak performance of the noise canceling mic.
- A volume control is provided for each ear dome.



OPERATIONAL TIPS

If the aircraft does not have a built-in push-to-talk (PTT) switch, a portable PTT switch must be installed in order to use the radio. The master gain control located in the aircraft radio should be optimized by an avionics technician whenever adding a new model microphone to the system.

TROUBLESHOOTING

Feedback (Squealing):

- The mic boom should always be worn from the left side. Speaker placements in this ANR system are calibrated for this configuration. Wearing the mic boom from the right may result in feedback (squealing).
- Be sure the ear seals are against the head on both sides.
- The electronics and acoustical cavity of the ear cup were tuned to the characteristics of the Flightcom ear seals, and we recommend that you only use Flightcom replacement parts when performing recommended annual hygiene maintenance. Installing incorrect ear seals may result in improper fit and feedback (squealing).

Volume too loud (or soft) in one ear dome:

Adjust volume using control knob on each ear dome to achieve comfortable volume balance.

No sound in one ear dome:

Switch to "M" on the M/S (Stereo/Mono) switch next to clip on ANR battery pack.

Blinking red LED on battery pack:

Battery voltage is low and needs replacing.

No light on battery pack:

ANR is switched off, or battery needs replacing.

SPECIFICATIONS

Headset: Classic ANR

Sensitivity ANR off:	98 dB re .0002 microbar @ 1000 Hz, 1mW
Sensitivity ANR on:	110 dB re .0002 microbar @ 1000 Hz, 1mW
Frequency Response:	20-10,000 Hz +/- 10 dB in 6cc coupler
Impedance:	300 ohms nominal, 150 to 1200 ohm source
Weight:	17.6 ounces without comm cable
Weight of comm cable:	4.0 ounces
Shielded cable:	Full floating with independent ground

Microphone:

DC Bias Supply:	8 to 16 volts, not polarity sensitive
Source Resistance:	220 to 2200 ohms
Output Voltage:	370 mV @ 114 dB spl re .0002 microbar
Frequency Response:	Optimized for speech clarity and noise reduction
Maximum Ambient Noise Level:	120 dB spl re .0002 microbar

Caution:

Bias voltage supplied to the microphone must come from voltage and resistance ranges specified above. Voltages supplied in excess of those stated in the specifications can cause microphone failure and void warranty. The mic audio signal is present between the ring and barrel of the mic plug; tip is reserved for transmit keyline.

Inside each ear cup of your headset you will notice an oval fabric piece. This is intended to prevent debris from entering the speaker element and to help prevent feedback of the ANR system. Do not operate the ANR modules without these fabric pieces in place.

WIRING DIAGRAM

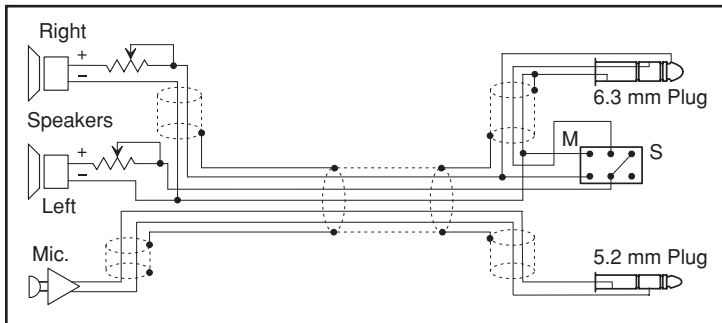

ANR circuitry is not represented in this diagram.
Questions? Call toll free 1-800-432-4342

Replacing the Battery:

Do not use rechargeable batteries.
To install or replace the ANR Battery, open the battery door by sliding the door in a downward motion till it unlatches, and lift up as shown in diagram A.

Slide the 9 volt battery in with the large battery contact on the bottom. If you put the battery in upside down, it will not activate.
See diagram B.

Battery life is dependent on the ambient noise in the aircraft, but should provide an average of 20 hours of continuous use.

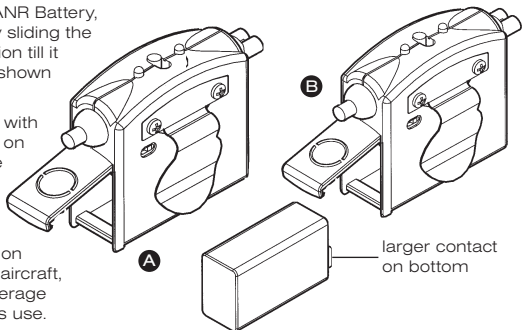

Three-Year Limited Warranty to Original Purchaser

Flightcom Corporation warrants to the original purchaser of this product that it will be free from defects in materials and workmanship, under normal and proper use, for the period of three years from date of purchase. Flightcom Corporation will repair or replace, at its sole option, any parts showing factory defects during this warranty period, subject to the following provisions. This warranty applies only to a new product which has been sold through authorized channels of distribution. All work under warranty must be performed by Flightcom Corporation. All returned products must be shipped to our address, freight prepaid, accompanied by a dated proof of purchase. **SAVE YOUR SALES SLIP!** The purchaser voids this warranty if he, she or others attempt to repair, service or alter the product in any way. This warranty does not apply in the event of accident, abuse, improper installation, unauthorized repair, tampering, modification, fire, flood, collision or other damage from external sources, including damage which is caused by user replaceable parts (leaking batteries, etc.). This warranty does not extend to any other equipment or aircraft to which this product may be attached or connected. The foregoing is your sole remedy for failure in service or defect. Flightcom Corporation shall not be liable under this or any implied warranty for incidental or consequential damages, nor for any installation or removal costs or other service fees. This warranty is in lieu of all other warranties, express or implied, including the warranty of merchantability or fitness for use, which are hereby excluded. To the extent that this exclusion is not legally enforceable, the duration of such implied warranties shall be limited to three years from date of purchase. No suit for breach of express or implied warranty may be brought after three years from date of purchase.



FLIGHTCOM CORPORATION

17600 SW 65th Ave, Lake Oswego, OR 97035 USA
800-432-4342 • service@flightcom.net • flightcom.net

Copyright © 2019 Flightcom Corporation. All rights reserved.
Flightcom is a registered trademark of Flightcom Corporation.
Specifications subject to change without notice.